

1. SAFETY INSTRUCTIONS

1.1 ELECTRICAL SAFETY

- ❑ **WARNING!** It is the responsibility of the Installer, owner and operator to read, understand and comply with the following:
 - 1.1.1 All electrical wiring must be carried out by a fully qualified Electrician in accordance with the current IEE wiring regulations.
 - 1.1.2 An isolator having a contact separation of at least 3mm on all poles must be incorporated in the fixed wiring as a means of fully disconnecting the mains supply.
 - 1.1.3 The Circuit should also be protected by a suitably rated fuse, MCB or RCBO.
 - 1.1.2 The electrical supply must be isolated before removing the front cover.
 - 1.1.3 **MAXIMUM LOAD MUST NOT EXCEED 16 AMPS**

2. SPECIFICATION

Sensing Element	Gas Bellows	Switch Type	S.P.S.T
Switch Rating	230V / Volt Free	Current Rating	16(4)Amp Max
Temperature Range	5°C to 35°C	Dimensions	W 83mm x H 83mm x D 45mm
Switching Differential	≤ 1.5°C	Fixing method	Surface or standard recessed metal box

The Thermostat is a Class II (double insulated) device.

Complies with EN60730-1, EN60730-2.7, EMC Directive 2004/108/EC, LVD Directive 2006/95/EC

3. INSTALLATION INSTRUCTIONS

Location - The RST3-IN should be wall-mounted at approximately 1.5m above floor level. Do not position above a radiator or in direct sunlight. Set the temperature before closing the lid. Temperature reading is at 12O'clock, drawings show setting at 20°C.

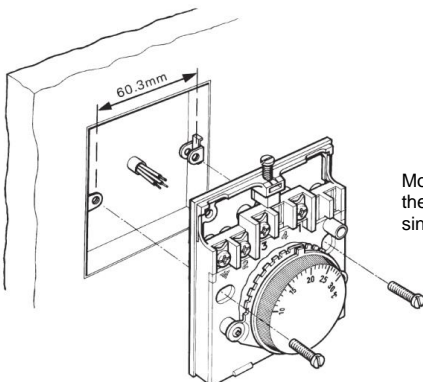
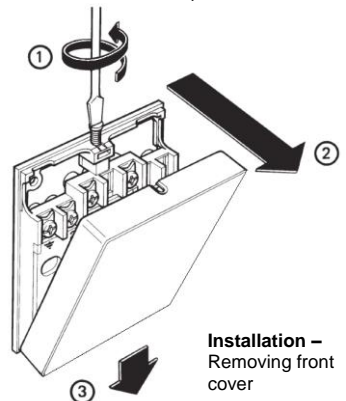
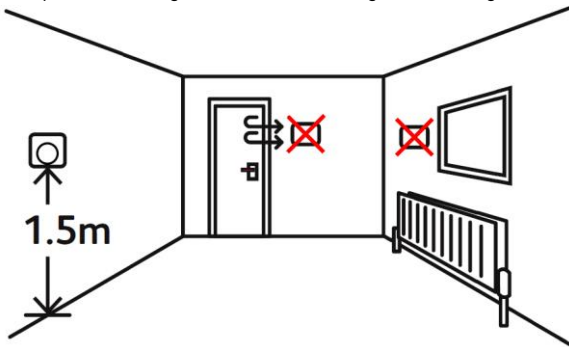

Mounting and wiring the thermostat to a standard single recessed metal box.

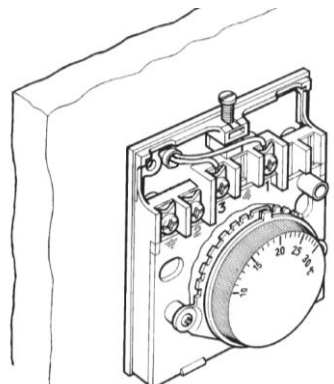

Surface mounting and wiring the thermostat.

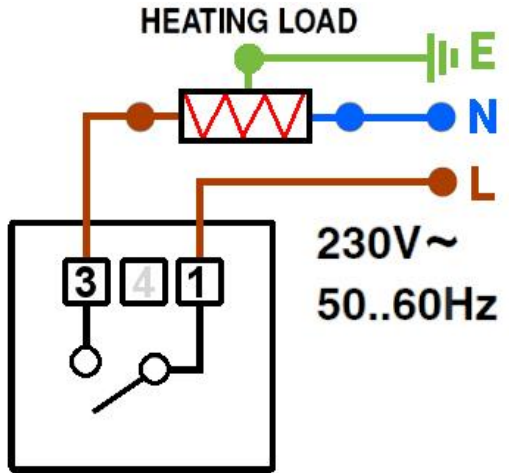
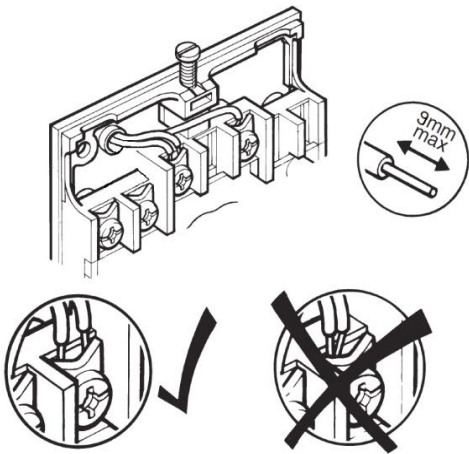
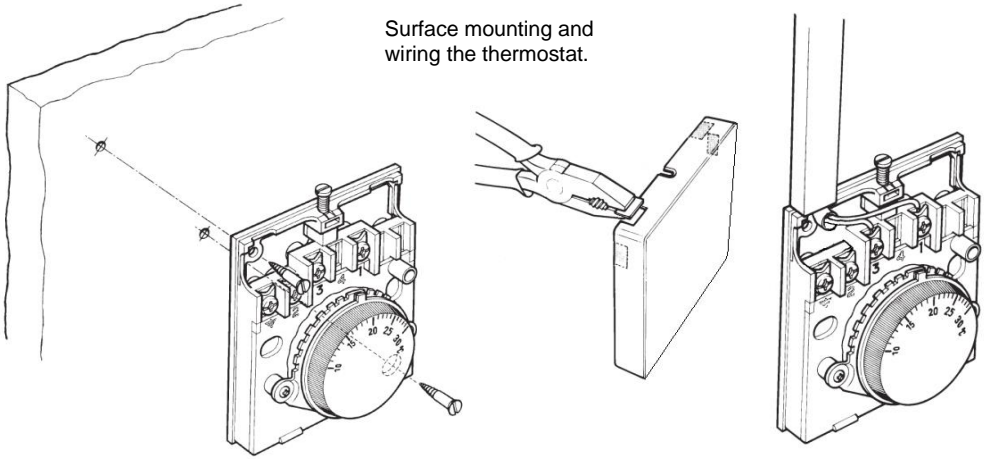

NOTE: It is our policy to continually improve products and as such we reserve the right to alter data, specifications and component parts without prior notice.



WEEE REGULATIONS:

This appliance bears the symbol of the crossed waste bin. This indicates that, at the end of its useful life, it must not be disposed of as domestic waste, but must be taken to a collection centre for waste electrical and electronic equipment. It is the user's responsibility to dispose of this appliance through the appropriate channels. Failure to do so may incur penalties established by laws governing waste disposal.

IMPORTANT: No liability is accepted for incorrect use of this product.

WARRANTY: Your BN Thermic product is guaranteed for one year from date of purchase. We will repair or replace at our discretion any part found to be defective. We cannot assume any consequential liability. This guarantee in no way prejudices your rights under common law and is offered as an addition to consumer liability rights.

BN Thermic Ltd,
34 Stephenson Way,
Crawley, RH10 1TN
Tel: +44 (0) 1293 547361
sales@bnthermic.co.uk
www.bnthermic.co.uk