

Thank you for purchasing a BN Thermic product. Manufactured to a high standard, this product will, if used according to these instructions and properly maintained, give you years of trouble free performance.



REGISTER: PLEASE REGISTER THIS PRODUCT ONLINE TO ACTIVATE YOUR GUARANTEE AT
www.bnthermic.co.uk



IMPORTANT: PLEASE READ THESE INSTRUCTIONS, NOTE THE SAFE OPERATIONAL REQUIREMENTS, WARNINGS, AND CAUTIONS. USE THIS PRODUCT CORRECTLY, AND WITH CARE FOR THE PURPOSE FOR WHICH IT IS INTENDED. FAILURE TO DO SO MAY CAUSE DAMAGE AND/OR PERSONAL INJURY AND WILL INVALIDATE THE WARRANTY.

1. SAFETY INSTRUCTIONS

1.1 ELECTRICAL SAFETY

WARNING! It is the responsibility of the owner and the operator to read, understand and comply with the following:

You must check all electrical products, before use, to ensure that they are safe. You must inspect power cables, plugs, sockets and any other connectors for wear or damage. You must ensure that the risk of electric shock is minimised by the installation of appropriate safety devices. A Residual Current Circuit Breaker (RCCB) should be incorporated in the main distribution board. If in any doubt consult a qualified electrician.

You must also read and understand the following instructions concerning electrical safety.

- The Health & Safety at Work Act 1974 makes owners of electrical appliances responsible for the safe condition of those appliances and the safety of the appliance operators. If in any doubt about electrical safety, contact a qualified electrician.
- Installation should always be carried out by a qualified electrician or a competent person in accordance with current electrical regulations.
- Ensure that the cables are always protected against short circuit and overload.
- Regularly inspect the power supply cables and plugs etc. for wear or damage and check all connections to ensure that none are loose.
- Important: Ensure that the voltage marked on the appliance matches the power supply to be used and that a correctly rated fuse is fitted.
- DO NOT use worn or damaged cables, plugs or connectors. Immediately have any faulty item repaired or replaced by a qualified electrician.
- The unit should be protected by a suitably rated isolator and type C MCB or Type C RCBO. An inrush current (initial current through the lamp) can be expected at switch on. This current can be as high as 12 times the normal operating current, lasting less than 20 milliseconds. This effect can also vary depending on temperature. In extreme cases, a type D breaker may be required.
- This heater is IP20 rated and is suitable for indoor or under cover use only.
- The mains lead is made from high temperature Silicone rated at 180°C and MUST not be replaced without using the same type cable. This replacement if necessary, MUST only be carried out by a fully qualified electrician.
- Ensure that the mounting bracket is adequately earthed.
- Do not attach this heater to an extension cord it must be hard wired in position.

1.2 GENERAL SAFETY INSTRUCTIONS

- ✓ Remove all packaging and store it away from children, check the package and heater for visible damage or tampering.
- ✓ Ensure the heater is in good order and condition both physically and electrically before use. If in any doubt, do not use the unit and contact your supplier.
- ✓ Only use recommended attachments and parts. To use unauthorised parts may be dangerous and will invalidate your warranty.
- ✓ Check that the lamp guard is in place, undamaged and firmly attached.
- ✓ Keep children and unauthorised persons away from the heater, as it gets **very hot**.
- ✓ Disconnect from mains and allow to cool before moving or attempting any cleaning or maintenance.
- X **DO NOT** use in areas where hazardous vapours may be present.
- X **DO NOT** locate the heater below the power outlet.
- X **DO NOT** move the heater whilst in operation or even when still warm.
- X **DO NOT** touch the heater lamp, even when cold.
- X **DO NOT** disassemble the heater for any reason. This heater must be checked by qualified personnel only.
- X **DO NOT** use this heater to perform a task for which it has not been designed.
- ❑ **WARNING!** Never touch the lamp directly with your fingers. Use a soft clean cloth otherwise the lamp may get damaged.
- ❑ **WARNING!** This heater is not equipped with a device to control the room temperature. Do not use this heater in a small room if it is occupied by people not capable of leaving the room on their own, unless constant supervision is provided.
- ❑ **WARNING!** Ensure you observe the safety distance (see Fig.1) and there is no possibility of inflammable materials coming into contact.



HN3-30 + CS2 Switch
 Shown in ivory also available in black



Other Heaters available in this series



2. INTRODUCTION & SPECIFICATION

This heater produces a totally dry heat, no condensation, no gas, no fumes and no smell. It reaches maximum heat output within seconds of being turned on. It has a highly polished aluminium reflector for maximum heat efficiency. It adjusts horizontally while mounted and is ideal for industrial or domestic applications. It can also be used in conjunction with our Halogen Multi Heater Control Box (See Item - HC2).

Model	HN3-30(B)
Power	3000W
Input supply	220-240v
Dimensions (W x H x D)	375 x 376 x 100mm
Weight	4.6kg
Minimum Mounting Height	2.2M
Recommended Mounting Height	2.5M
Recommended Maximum Mounting Height	3.5M
Safety Distance from Heater	1.5M

3. MOUNTING INSTALLATION

3.1 WALL MOUNTING (Fig.1)

- ❑ **IMPORTANT!** The following points should be noted: *The heater should always have a minimum clearance of 400mm from a ceiling and at least 1500mm from any object (see table above).*
- ❑ **IMPORTANT!** Ensure that the mounting surface is capable of supporting the weight of the heater.
- ❑ **IMPORTANT!** The heater should be mounted at 30° to 45° from the vertical, when wall mounted.
- ❑ **IMPORTANT!** The mounting bracket must be sufficiently earthed.

- 3.1.1 Remove the wall mounting bracket from the box.
- 3.1.2 Before drilling, ensure that there are no wires or water pipes in the area where the heater is to be placed.
- 3.1.3 Use the bracket as a template. Fix the metal bracket to the wall by means of the three holes and appropriate fixings (not supplied).
- 3.1.4 Refit the heater onto the bracket with the bolt provided.
- 3.1.5 Adjust the angle of heater to direct heat where required, between 30° and 45° (see Fig.1).

3.2 CEILING MOUNTING

- 3.2.1 An optional pack containing 4 hooks and nuts is available from your supplier to enable the heater to be ceiling mounted on suitable chains. (Product Code:- HSK)
- 3.2.2 Insert these 4 hooks into the M6 threaded holes in the back corners of the heater and lock in place with the supplied nuts.
- 3.2.3 Heaters can be hung horizontal to the floor. If hung at an angle this should ideally be 10° to 45° making sure the lamp remains in a horizontal position to the floor.

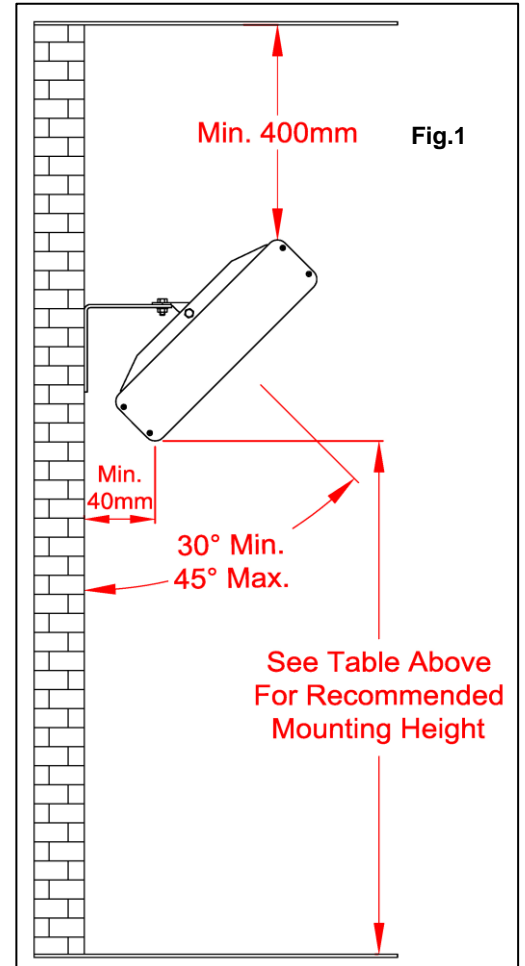

4. ELECTRICAL CONNECTIONS

4.1 230v INSTALLATION

- 4.1.1 Please make sure you have read the Safety instructions and you are a suitably qualified electrician before continuing.
- 4.1.2 All heater models are factory fitted with high temperature silicon rubber flexible cable conforming to BS 6500 having a temperature rating of 180°C. If necessary only replace with the same specification cable or a cable that will withstand 65°C continuous temperatures.
- 4.1.3 Heaters must be earthed.
- 4.1.4 It is advised that Type C MCBs or Type C RCBO,s is used due to the inrush current present when initially turning on halogen heaters – See front page for further information.
- 4.1.5 Connection to a Switched Isolator.
 - a) Connect the GREEN/YELLOW earth wire to the earth connection.
 - b) Connect the BROWN live wire to the live connection.
 - c) Connect the BLUE neutral wire to the neutral connection.
 - d) After wiring, check that there are no bare wires, that all wires have been correctly connected, that the cable outer insulation extends beyond the cable restraints and that the restraint is tight.

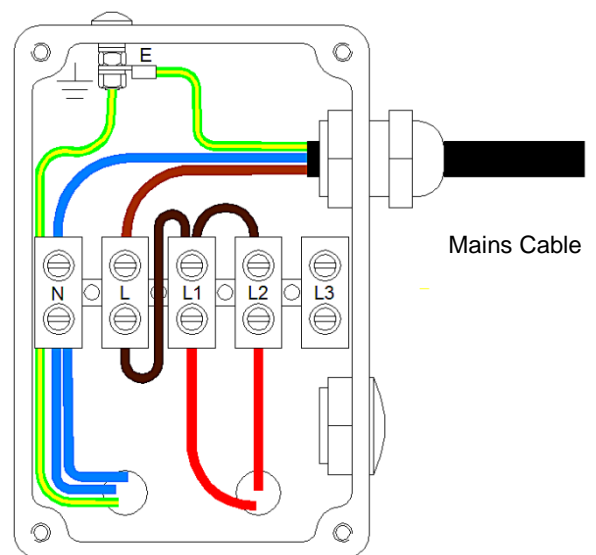
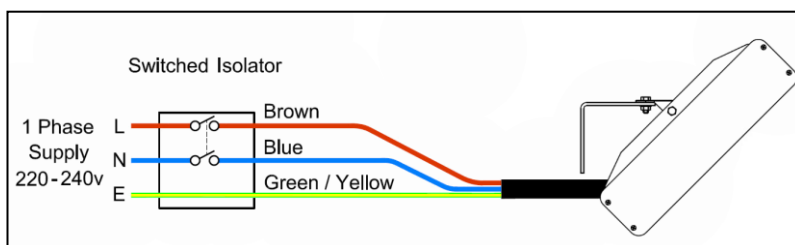

Internal View of Connection Box

5. CONNECTING A CS-2 CONTROL SWITCH TO THE HEATER

CS-2 control switch box can be easily connected to the HN3-30 Heater. This will allow the heater to be operated with one or two lamps controlling the heat output.

Please make sure you have read the Safety instructions and that you are a suitably qualified electrician before continuing.

Drawings show connections inside the terminal box on the outside of the heater and the inside of the CS2 Controller.

Please Note:- Specified cable sizes are for typical installations, correction factors may need to be used when determining actual cable sizes.

Follow the following instructions to connect the heater to CS-2 Switch Box

- Open terminal box on back of heater.
- Remove blanking plug in the heater connecting box and fit cable gland to suit cable you are using (not supplied).
- Remove Brown Link cable between L - L1 and L1 - L2.
- Use 4 core silicon cable having a temperature rating of 180°C or other suitable cable that will withstand 65°C continuously.
- Connect the cable as per drawings below.
- Switch box CS2 MUST be earthed.

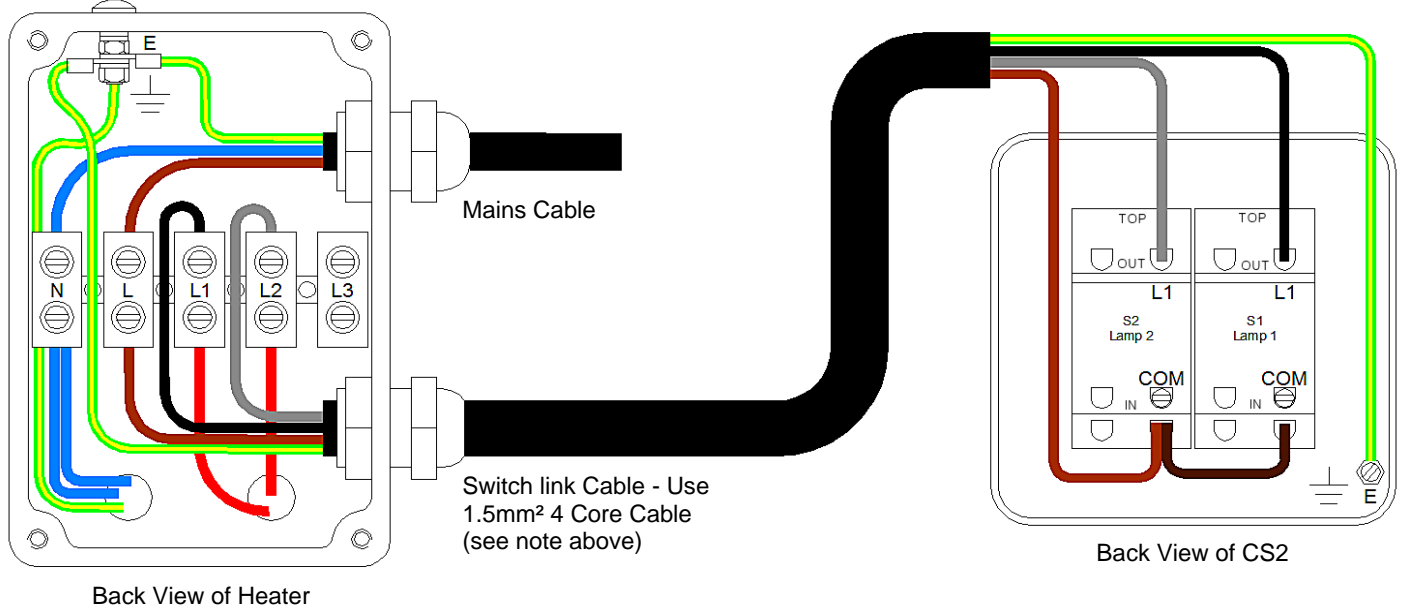

6. CONNECTING CONTROLS TO MULTI-HEATERS

Our HC2 multi heater control box provides variable output control of halogen heaters from a single point. This approach allows the intensity of heat to be adjusted by means of a simple wall-mounted controller, enhancing comfort and improving economy. It incorporates "soft start" which reduces shock loads on the power supply and increases lamp life by up to 10%. By using additional HC2 control boxes, the number of heaters controlled from a single point is almost endless. All control connections are made by Cat5 cable for super-quick and error-free installation. Frost thermostats and a countdown / run-down timer can easily be added to make this controller fully compatible with your exact requirements. Each system requires one wall controller.

If you require further information on multi-heater controllers, please contact us using the number on the back page.

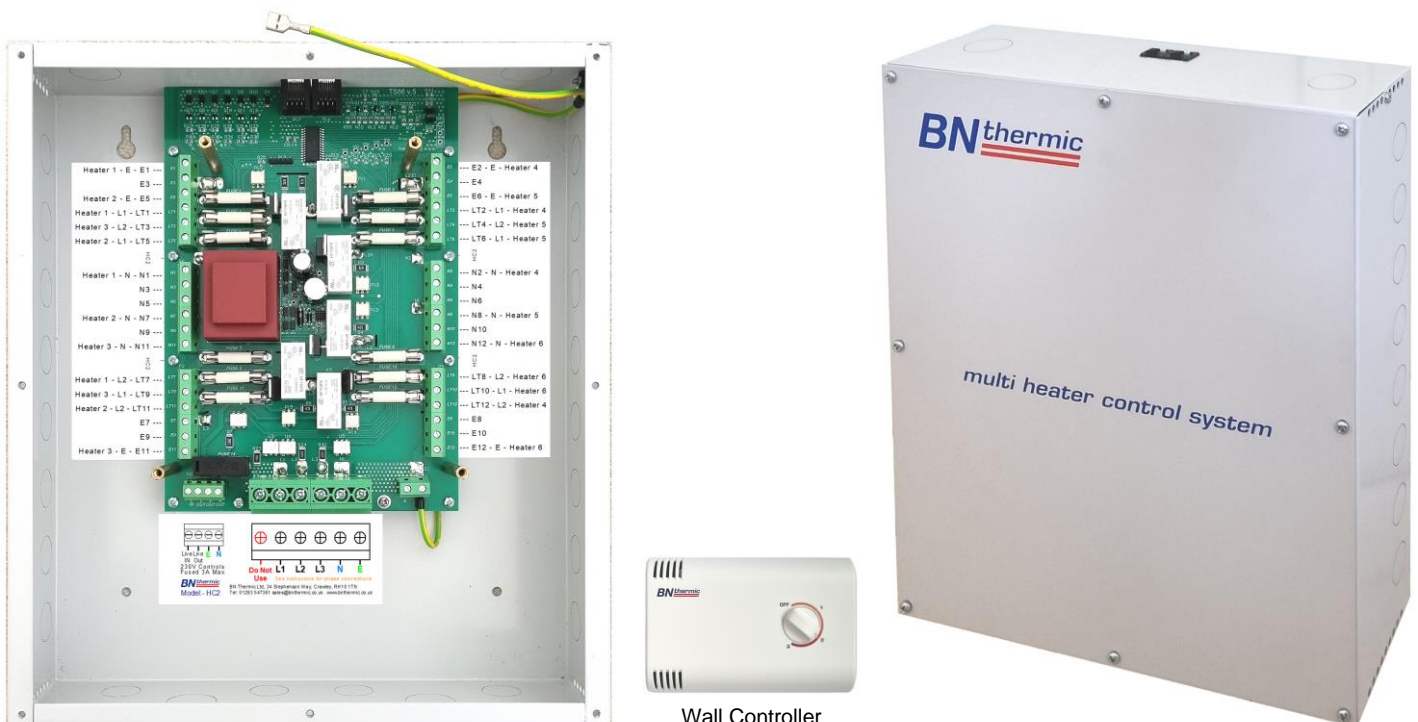

7. COMMISSIONING

Note: The infrared lamps in the heater are fragile as such it is important that they are not subjected to any unnecessary shocks or vibration and are not moved when in use. Wait till the heater has cooled down before moving / adjusting.

WARNING! Ensure you read, understand and apply the safety instructions in Section 1 before using the heater.

- 7.1 Perform Insulation and Earth continuity tests.
- 7.2 Switch on the heater(s) and confirm that the lamps are working.
- 7.3 Ensure each heater aims its warmth into the target area by adjusting the heater angle(s) as required, and then tighten the bracket bolts keeping the heater(s) firmly in place.
- 7.4 Although the fitting can be tilted between 30° & 45° in the vertical plane, check & ensure that the fitting remains within 10° of the horizontal plane as the lamps are only designed for horizontal operation.
- 7.5 The User / Customer should be made aware of all aspects of the operation and safety advice. Keep the instructions safely for future reference.
- 7.6 In unoccupied premises it is recommended that the heating system is switched off and isolated from the electrical supply.

Magic Lamps (if installed) are designed to glow red for a few minutes before dimming to a gentle pink glow.

8. MAINTENANCE

Note: Before examining or carrying out any maintenance ensure the heater has cooled down and is disconnected from the mains supply.

- 8.1 BN Thermic infrared quartz heaters contain no moving parts and therefore very little maintenance is required other than to ensure that there is no excessive build-up of dust/dirt on the reflectors or lamps as this can cause overheating and premature lamp failure. Depending on installation conditions, a heater should be regularly inspected, but at least once per year.

9. LAMP REPLACEMENT

Note: Before examining or carrying out any maintenance ensure the heater has cooled down and is disconnected from the mains supply. The lamp used in the fitting is robust and if knocks and shock vibrations are avoided, will last for around 7000 hours.

Lamp Installation (if required) or replacement

- 1) Undo the 4 screws on each end cover, and remove the covers (Pic. A).
- 2) Unscrew the 4 screws securing the guard (Pic. B), remove guard and slide out the end reflectors.

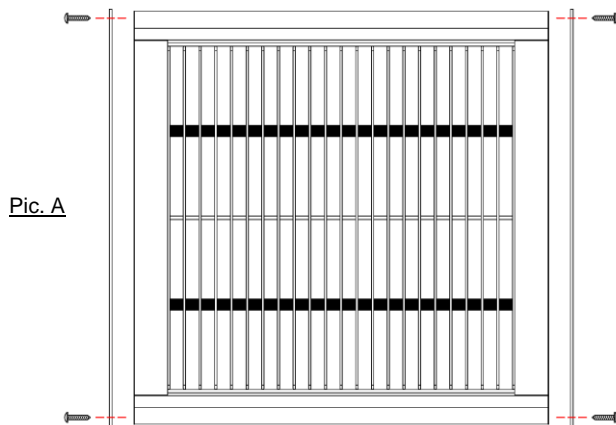

Pic. A

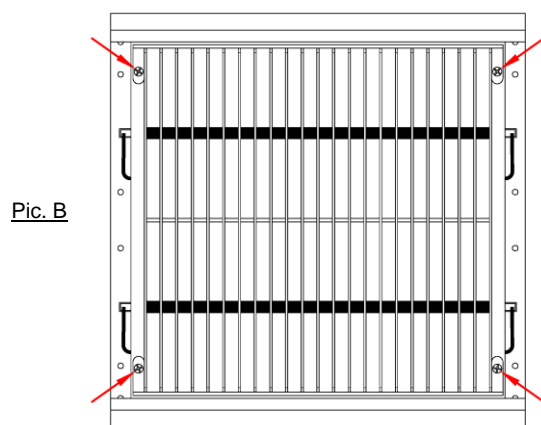

Pic. B

- 3) If replacing lamp unscrew lamp leads and remove lamp.
- 4) Carefully remove new lamp from its box making sure you do not touch the glass part of the lamp, centre lamp to brackets with leads pointing downwards.
- 5) Insert each end of lamp halfway under each spring clip.
- 6) Push slowly each end of lamp with equal thumb pressure fully into clips (Pic. C).
N.B. Any inadvertent finger marks on the glass lamp can be removed using methylated spirits on a soft cloth.
- 7) Connect lamp leads to connector blocks. Tighten screws.
- 8) Re-assemble heater by sliding the end reflectors back, then secure the guard in position with the 4 screws.
- 9) Refit the end covers making sure no wires are trapped before tightening the screws.
- 10) **WARNING!** Failure to reassemble all the parts and use the guard will invalidate any remaining guarantee and may make the unit dangerous.

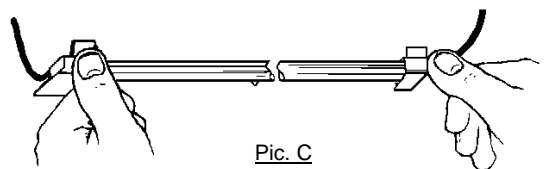

Pic. C

10. SPARES

Note: Spare Lamps are available from your distributor. Please quote the following Lamp codes when requesting spares

Heater Model	HN3-30(B)	HN3-30(B)M	
Replacement Lamp Code	RL15GF	RL15MF	



WEEE REGULATIONS:

This appliance bears the symbol of the crossed waste bin. This indicates that, at the end of its useful life, it must not be disposed of as domestic waste, but must be taken to a collection centre for waste electrical and electronic equipment. It is the user's responsibility to dispose of this appliance through the appropriate channels. Failure to do so may incur penalties established by laws governing waste disposal.

NOTE: It is our policy to continually improve products and as such we reserve the right to alter specifications and component parts without prior notice.

IMPORTANT: No liability is accepted for incorrect use of this product.

WARRANTY: Your BN Thermic product is guaranteed for one year from date of purchase. We will repair or replace at our discretion any part found to be defective. We cannot assume any consequential liability. This guarantee in no way prejudices your rights under common law and is offered as an addition to consumer liability rights.

REGISTER: Activate your warranty by registering online at www.bnthermic.co.uk and retain this installation data for future reference.

HN3-2INS-v01-2

BN Thermic Ltd,
34 Stephenson Way,
Crawley, RH10 1TN
Tel: +44 (0) 1293 547361
sales@bnthermic.co.uk
www.bnthermic.co.uk