

Thank you for purchasing a BN Thermic product. Manufactured to a high standard, this product will, if used according to these instructions and properly maintained, give you years of trouble free performance.



REGISTER: PLEASE REGISTER THIS PRODUCT ONLINE TO ACTIVATE YOUR GUARANTEE AT
www.bnthermic.co.uk



IMPORTANT: PLEASE READ THESE INSTRUCTIONS, NOTE THE SAFE OPERATIONAL REQUIREMENTS, WARNINGS, AND CAUTIONS. USE THIS PRODUCT CORRECTLY, AND WITH CARE FOR THE PURPOSE FOR WHICH IT IS INTENDED. FAILURE TO DO SO MAY CAUSE DAMAGE AND/OR PERSONAL INJURY AND WILL INVALIDATE THE WARRANTY.

1. SAFETY INSTRUCTIONS

1.1 ELECTRICAL SAFETY

- WARNING!** It is the responsibility of the owner and the operator to read, understand and comply with the following:
You must check all electrical products, before use, to ensure that they are safe. You must inspect power cables, plugs, sockets and any other connectors for wear or damage. You must ensure that the risk of electric shock is minimised by the installation of appropriate safety devices. A Residual Current Circuit Breaker (RCCB) should be incorporated in the main distribution board. If in any doubt consult a qualified electrician.
You must also read and understand the following instructions concerning electrical safety.
- 1.1.1 The Health & Safety at Work Act 1974 makes owners of electrical appliances responsible for the safe condition of those appliances and the safety of the appliance operators. If in any doubt about electrical safety, contact a qualified electrician.
- 1.1.2 Ensure that the cables are always protected against short circuit and overload.
- 1.1.3 Regularly inspect the power supply cables and plugs etc. for wear or damage and check all connections to ensure that none are loose.
- 1.1.4 Important: Ensure that the voltage marked on the appliance matches the power supply to be used and that a correctly rated fuse is fitted.
- 1.1.5 DO NOT pull or carry the appliance by the power cable.
- 1.1.6 DO NOT use worn or damaged cables, plugs or connectors. Immediately have any faulty item repaired or replaced by a qualified electrician.
- 1.1.7 Installation should always be carried out by a qualified electrician or a competent person in accordance with current electrical regulations.
- 1.1.8 The unit should be protected by a suitably rated isolator and a type C MCB or Type C RCBO. An inrush current (initial current through the lamp) can be expected at switch on. This current can be as high as 12 times the normal operating current, lasting less than 20 milliseconds. This effect can also vary depending on temperature. In extreme cases, a type D breaker may be required.
- 1.1.9 This heater is IP55 rated and is suitable for outdoor use. To maintain the protection rating all connections to the mains must be done with a minimum of IP55 equipment.
- 1.1.10 The mains lead is made from high temperature cable, not a standard PVC cable and as such should not be replaced without consulting a suitable qualified electrician.
- 1.1.11 Ensure that the mounting bracket is adequately earthed.
- 1.1.12 Use of an extension cord is not recommended.

1.2 GENERAL SAFETY INSTRUCTIONS

- ✓ Remove all packaging and store it away from children, check the package and heater for visible damage or tampering.
- ✓ Familiarise yourself with the applications and limitations of the heater.
- ✓ Ensure the heater is in good order and condition both physically and electrically before use. If in any doubt do not use the unit and contact an electrician.
- ✓ Only use recommended attachments and parts. To use unauthorised parts may be dangerous and will invalidate your warranty.
- ✓ Check that the lamp guard is in place, undamaged and firmly attached.
- ✓ Keep children and unauthorised persons away from the heater, as it gets **very hot**.
- ✓ Disconnect from mains and allow to cool before moving or attempting any cleaning or maintenance.
- X **DO NOT** install in areas where hazardous vapours may be present.
- X **DO NOT** subject the heater to prolonged exposure to water. The product is IP55 rated.
- X **DO NOT** locate the heater below the power outlet.
- X **DO NOT** move the heater whilst in operation or even when still warm.
- X **DO NOT** disassemble the heater for any reason. This heater must be checked by qualified personnel only.
- X **DO NOT** use this heater to perform a task for which it has not been designed.
- ✓ If removed from its mounting position when not in use, store the heater carefully in a safe, dry, child proof location.
- WARNING!** Never touch the lamp directly with your fingers. Use a soft cloth, otherwise the tube may get damaged.
- WARNING!** This heater is not equipped with a device to control the room temperature. Do not use this heater in a small room if it is occupied by people not capable of leaving the room on their own, unless constant supervision is provided.
- WARNING!** Ensure the heater is at least 1m from any object and there is no possibility of inflammable materials coming into contact.

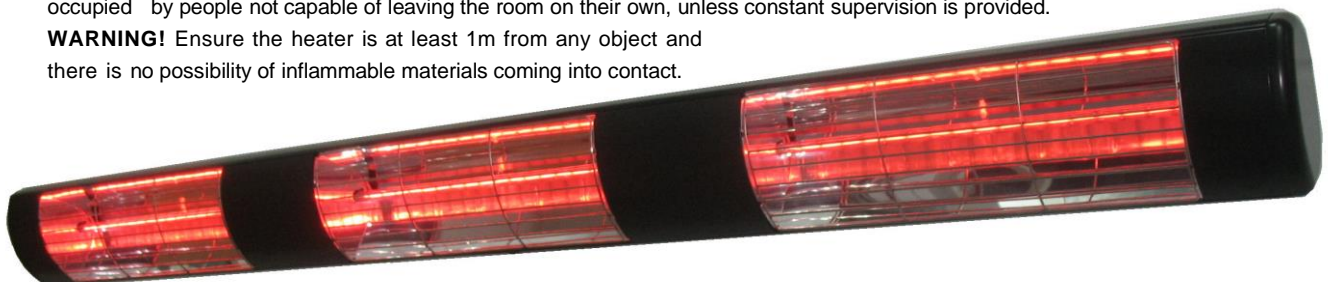

2. INTRODUCTION & SPECIFICATION

This heater produces a totally dry heat, no condensation, no gas, no fumes and no smell. It reaches maximum heat output within seconds of being turned on and has a highly polished aluminium reflector for maximum heat efficiency. It adjusts horizontally through 90° while mounted. And is ideal for industrial or domestic applications, IP55 rated.

Model	HWP2-45B	HWP2-45BM
Power	4500W	4500W
Input supply	230V 50Hz 19.5A	230V 50Hz 19.5A
Dimensions (W x H x D)	1440 x 125 x 125mm	1440 x 125 x 125mm
Mounting Bracket Stand Off	45mm	45mm
Minimum Mounting Height	1.8m	1.8m

3. MOUNTING INSTALLATION

3.1 WALL MOUNTING (fig.1)

- ❑ **IMPORTANT!** The following points should be noted: *The heater should always have a minimum clearance of 500mm from a ceiling and at least 1000mm from any object.*
 - ❑ **IMPORTANT!** Ensure that the mounting surface is capable of supporting the weight of the heater.
 - ❑ **IMPORTANT!** The heater should be mounted horizontally where possible or at a maximum angle of 35 degrees from the horizontal.
 - ❑ **IMPORTANT!** The mounting bracket must be sufficiently earthed.
- 3.1.1 Remove the wall mounting bracket from the heater by removing the two bolts from either end of the bracket.
 - 3.1.2 Before drilling ensure that there are no wires or water pipes in the area where the heater is to be placed.
 - 3.1.3 Use the bracket as a template. Fix the metal bracket to the wall by using a minimum of 3 holes and appropriate fixings (not supplied).
 - 3.1.4 Refit the heater back onto the bracket
 - 3.1.5 Adjust the angle of heater to direct heat where required, between 45° and 90° (see fig.1).
 - 3.1.6 Now tighten up the two bolts tightly.

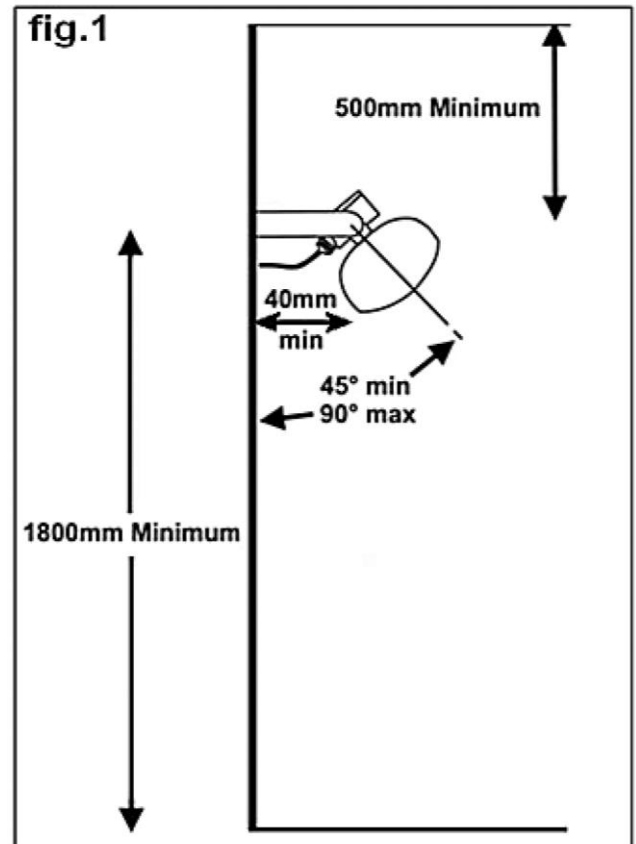

3.2 ELECTRICAL CONNECTION

- 3.2.1 Please make sure you have read the Safety instructions and you are a suitably qualified electrician before continuing. Note: If the power circuit is protected by an MCB or RCBO this needs to be a type C Breaker. The heater may cause Type B MCB's or RCBO's to trip when turned on! – See section 1.1.8 on the front page for further information.
- 3.2.2 If connecting to a 32A Round Pin Industrial Plug
 - a) Connect the GREEN/YELLOW earth wire to the earth terminal 'E'.
 - b) Connect the BROWN live wire to the live terminal 'L'.
 - c) Connect the BLUE neutral wire to the neutral terminal 'N'.
 - d) After wiring, check that there are no bare wires, that all wires have been correctly connected, that the cable outer insulation extends beyond the cable restraint and that the restraint is tight.
- 3.2.3 Connection to a Switched Fused Spur / Isolator.
 - a) Connect the GREEN/YELLOW earth wire to the earth connection.
 - b) Connect the BROWN live wire to the live connection.
 - c) Connect the BLUE neutral wire to the neutral connection'.
 - d) After wiring, check that there are no bare wires, that all wires have been correctly connected, that the cable outer insulation extends beyond the cable restraints and that the restraint is tight.

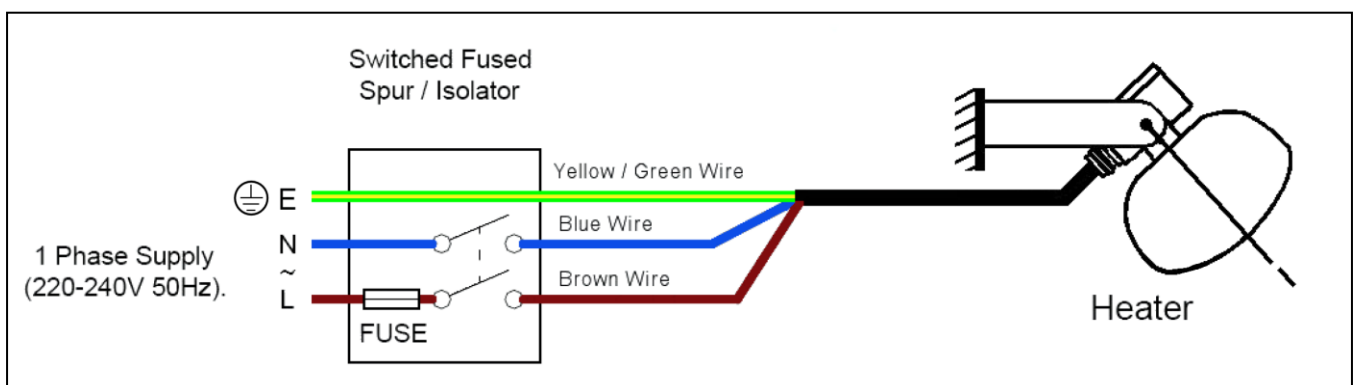

3.3 CONVERSION FROM SINGLE TO 3 PHASE

3.3.1 Please make sure you have read the Safety instructions and you are a suitably qualified 3phase electrician before continuing.

- a) Open electrical box on back of heater
- b) See drawing below - Undo the screw in the terminal block clamping the 3 live cables coming from the lamps.
- c) Move one of the cables to terminal marked L3
- d) Move the second cable to terminal marked L2
- e) Make sure the remaining cable is still in L1 and tighten up all the screws.
- f) **YOU SHOULD NOT NEED TO TOUCH ANY OF THE NEUTRAL CABLES COMING FROM THE LAMPS**
- g) Now remove the mains cable and replace with suitable rated 5core 3 phase cable. This must be high temperature silicon cable
- h) Heater needs to be connected L1, L2 L3, Neutral and Earth

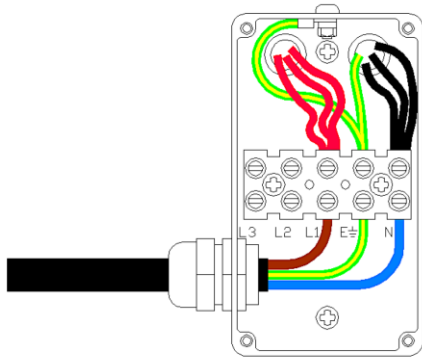

Single Phase

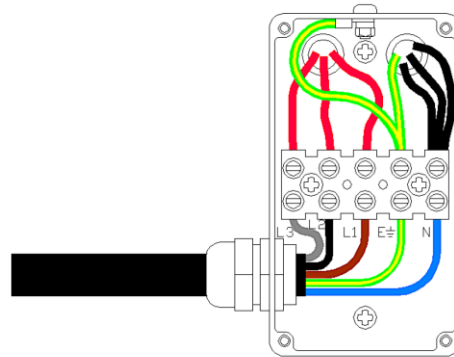

3 Phase

4. OPERATION

Note: The infrared lamps in this heater are fragile as such it is important that they are not subjected to any unnecessary shocks or vibration and is not moved when in use. Wait till the heater has cooled down before moving.

⚠ WARNING! Ensure you read, understand and apply the safety instructions in Section 1 before using the heater.

- 4.1 Ensure the heater is at least 1000mm from any object. The heater can be tilted from 45° to 90° set it to the required angle before switching the heater on. Adjust the heater angle by loosening the two bolts on the wall mounting bracket. Tighten the bolts again when the desired angle is reached.
- 4.2 Ensure that the mains supply is adequately protected and that the mounting bracket is earthed, then switch on.
- 4.3 Make sure the heater is disconnected from the mains supply before any cleaning is attempted. Also allow the heater to cool completely.
- 4.4 When the heater is no longer required, switch off and if possible, unplug / disconnect the unit.
- 4.5 Clean the exterior with a soft damp cloth.
- 4.6 To replace any of the lamps, contact your authorised dealer.
- 4.7 The mains lead is made from high temperature cable, not a standard PVC cable and as such should not be replaced without consulting a suitable qualified electrician.

5. MAINTENANCE

Note: Before examining or carrying out any maintenance ensure the heater has cooled down and is disconnected from the mains supply.

- 5.1 The heater contains no moving parts and therefore very little maintenance is required other than to ensure that there is no excessive build-up of dust/dirt on the reflectors or emitters as this can cause overheating and premature emitter failure. To clean the appliance, turn off and disconnect from mains supply, allow to cool then wipe with a damp cloth.

6. LAMP REPLACEMENT

Note: Before examining or carrying out any maintenance ensure the heater has cooled down and is disconnected from the mains supply.

The lamps used in the fitting are robust and if knocks and shock vibrations are avoided, will last for around 5000 hours. Please ensure you have the correct replacement lamp (see list below) before starting to dismantle the fitting.

6.1 TO REPLACE LEFT OR RIGHT LAMPS

- a) Make sure the heater is isolated and disconnect from the power supply, wait until the body of the heater has cooled down.
- b) Remove the end cap nearest the lamp you need to replace by undoing the 2 socket head screws at the end.
- c) Slide out the end cover plate and remove the guard and end reflector.
- d) Remove the other end reflector.
- e) Unclip the faulty lamp from the spring clips at each end, allowing the lamp to move forward clear of the back reflector.
- f) Unclip the reflector from the heater casing and remove.
- g) Now slid out the next cover plate making sure you don't drop the guard from the centre lamp. Gently remove the centre guard.
- h) Remove both end reflectors from the centre lamp.
- i) Remove the centre lamp back reflector by getting your fingers behind the reflector and unclipping it from its locating slot.
- j) Disconnect the faulty lamp wires from the terminals located in the electrical box on the rear of the heater, and then remove the lamp.

- k) Insert the wires of the new lamp through the holes in the heater body to the electrical box and reconnect them into the terminals. Ensure that the terminals are tightened correctly to make a good electrical connection.
- l) Re-assemble in the opposite order making sure all the parts are replaced and the guards are in position.

WARNING! Failure to reassemble all the parts and use the guards will invalidate any remaining guarantee and may make the unit dangerous.

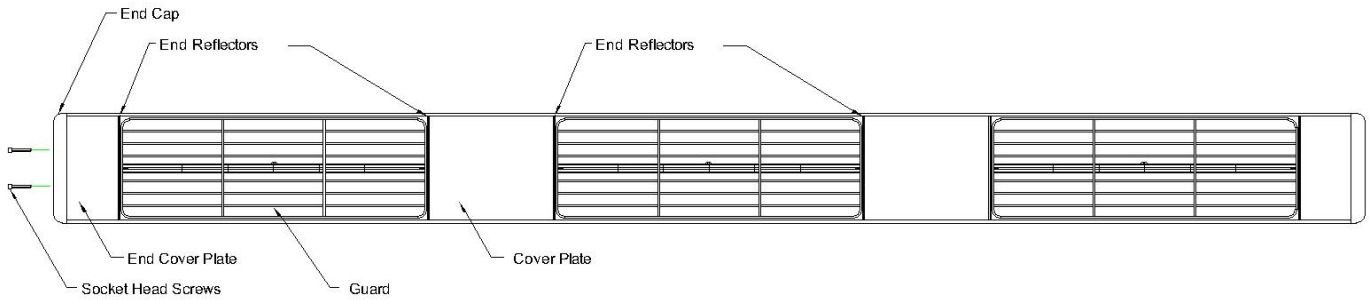

6.2 TO REPLACE CENTRE LAMP

- a) Make sure the heater is isolated and disconnect from the power supply, wait until the body of the heater has cooled down.
- b) Remove both end caps by undoing the 2 socket head screws at each end.
- c) Slide out both the end cover plates, remove the guards and end reflectors.
- d) Unclip both end lamps from their spring clips, allowing the lamp to move forward clear of the back reflector.
- e) Unclip the reflectors from the heater casing and remove.
- f) Now slid out the remaining 2 cover plates making sure you don't drop the guard from the centre lamp. Gently remove the centre guard.
- g) Remove both end reflectors from the centre lamp.
- h) Remove the centre lamp back reflector by getting your fingers behind the reflector and unclipping it from its locating slot.
- i) Disconnect the faulty lamp wires from the terminals located in the electrical box on the rear of the heater, and then remove the lamp. Ensure that the terminals are tightened correctly to make a good electrical connection.
- j) Insert the wires of the new lamp through the holes in the heater body to the electrical box and reconnect them into the terminals. Ensure that the terminals are tightened correctly to make a good electrical connection.
- k) Re-assemble in the opposite order making sure all the parts are replaced and the guards are in position.

WARNING! Failure to reassemble all the parts and use the guards will invalidate any remaining guarantee and may make the unit dangerous.

7. SPARES

Note: Spare are available from your distributor

Please quote the following Lamp codes when requesting spares

Heater Model	HLW45*G	HLW45*M	
Left Lamp Code	RL15GW/4	RL15MW/4	
Centre Lamp Code	RL15GW	RL15MW	
Right Lamp Code	RL15GW/4	RL15MW/4	



WEEE REGULATIONS:

This appliance bears the symbol of the crossed waste bin. This indicates that, at the end of its useful life, it must not be disposed of as domestic waste, but must be taken to a collection centre for waste electrical and electronic equipment. It is the user's responsibility to dispose of this appliance through the appropriate channels. Failure to do so may incur penalties established by laws governing waste disposal.

NOTE: It is our policy to continually improve products and as such we reserve the right to alter data, specifications and component parts without prior notice.

IMPORTANT: No liability is accepted for incorrect use of this product.

WARRANTY: Your BN Thermic product is guaranteed for one year from date of purchase. We will repair or replace at our discretion any part found to be defective. We cannot assume any consequential liability. This guarantee in no way prejudices your rights under common law and is offered as an addition to consumer liability rights.

REGISTER: Activate your warranty by registering online at www.bnthermic.co.uk and retain this installation data for future reference.

BN Thermic Ltd,
34 Stephenson Way,
Crawley, RH10 1TN
Tel: +44 (0) 1293 547361
sales@bnthermic.co.uk
www.bnthermic.co.uk